



BUILDING TRUST



INSTALLATION GUIDE

RMAX® ECOMAXCI® WALL SOLUTION INSTALLATION INSTRUCTIONS FOR CONTINUOUS INSULATION

Self-Adhered R-SEAL 3000 Tape and R-SEAL 6000 Flashing

RMAX: A BETTER INSULATION SOLUTION

Since 1978, Rmax has been manufacturing commercial, industrial and residential polyiso insulation products and providing engineered solutions for enhanced energy efficiency with less labor and materials. The ECOMAXci® Wall Solution for commercial buildings, featuring ECOMAXci® FR Air Barrier continuous insulation, is just one more example of our industry leadership in action.

Combining proven, high-performing thermal insulation board with Rmax branded tapes and flashings – the ECOMAXci® Wall Solution improves thermal efficiency and provides an Air Barrier Association of America (ABAA) evaluated solution to minimize air and water intrusion. The ECOMAXci® Wall Solution can be installed with self-adhered tapes and flashings or liquid applied flashings. ECOMAXci® FR Air Barrier is an approved component of the High Velocity Hurricane Zone (HVHZ) R-Trac System.

Refer to the corresponding Rmax ECOMAXci® FR Air Barrier Installation Instructions based on application needs:

1. Self-Adhered R-SEAL 3000 Tape and R-SEAL 6000 Flashing
2. Liquid Applied R-SEAL 2000 LF Liquid Flashing and Self-Adhered R-SEAL 6000 Flashing
3. Wind Resistance and High Velocity Hurricane Zone (HVHZ)

This document contains general information and installation instructions for the ECOMAXci® Wall Solution and must be followed in order for Rmax warranties to be valid. For additional information and compliance verification, refer to the current DrJ™ Engineering, LLC Technical Evaluation Report, "[TER 1212-03](#)". For warranty information, refer to the Rmax "[Sales Policy](#)" and "[ECOMAXci® Wall Solution Limited Warranty](#)".

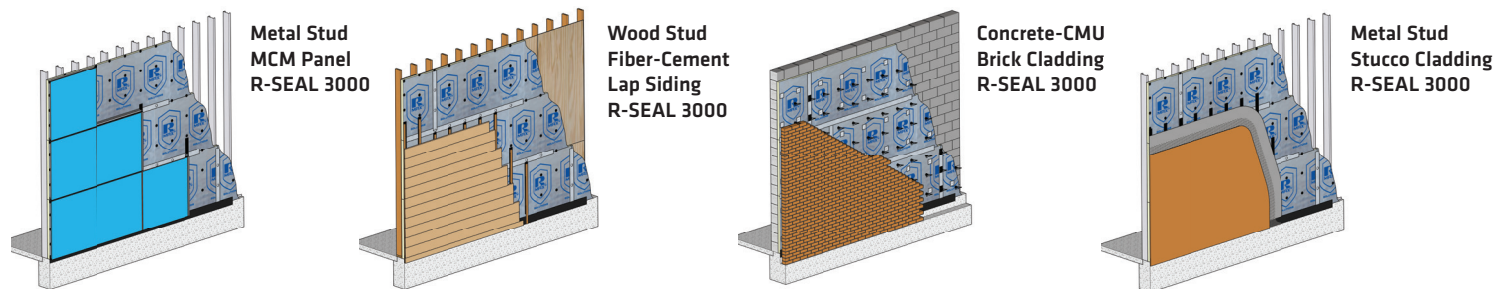

HANDLING, STORAGE AND PROTECTION REQUIREMENTS

- ECOMAXci® FR Air Barrier insulation boards are shipped in wrapped bundles, approximately 48" high. Exercise care during handling of insulation boards to prevent breaking or crushing of the edges and surfaces. Rmax requires that insulation bundles be unloaded from trucks by a fork-lift or similar equipment with suitable forks to slide under bundles. Do not roll or tumble bundles off delivery trucks.
- The factory packaging should not be relied upon as protection at job sites or other outdoor storage locations. Material delivery should be carefully coordinated with the construction schedule to minimize outdoor storage. When short-term storage is necessary, take the following precautions:
 - Store flat above ground (or other surface) on raised pallets.
 - Place bundles on finished surfaces, such as gravel, pavement, or concrete rather than on dirt or grass.
 - Cover package and pallet with a breathable tarpaulin and secure cover to prevent wind displacement.

BEFORE YOU BEGIN

Rmax highly recommends all details of the ECOMAXci® Wall Solution be discussed during all preconstruction meetings and mock-ups.

The design and construction of the exterior walls and supporting structure is the responsibility of the project architect, engineer, general contractor and the building owner. The structure must be designed to resist all live, dead, wind and construction loadings per governing building codes.

Establish a quality assurance program, such as the ABAA Quality Assurance Program (QAP), to ensure a continuous air and water-resistant barrier installation for the entire building envelope. Properly tie in and seal all air and water-resistant barrier systems used throughout the building envelope, including the Rmax ECOMAXci® Wall Solution, to provide complete continuity.

Follow OSHA safety and construction guidelines on the job site, as well as, local code requirements.

Prior to installation:

- Refer to the *Materials Checklist* for components and materials.
- Ensure compatibility of ECOMAXci® Wall Solution components and other materials with all building substrates and systems to which they tie into.
- Ensure all concrete and CMU is fully cured and wall framing has been erected.
- Clean surfaces and address irregularities that will affect the placement or performance of the ECOMAXci® Wall Solution components.

MATERIALS CHECKLIST [use as required within this document]

- ▶ Rmax ECOMAXci® FR Air Barrier Continuous Insulation†
- ▶ Rmax R-SEAL 3000 Tape†
- ▶ Rmax R-SEAL 6000 Flashing†
- ▶ Rmax R-SEAL 2000 LF Liquid Flashing†
- ▶ Trufast Walls Grip-Deck® Self Drilling Screws
- ▶ Trufast Walls Thermal-Grip® ci Prong Washers
- ▶ Trufast Walls Grip-Deck HiLo Thread Screws
- ▶ Trufast Walls Plasti-Grip PMF
- ▶ Trufast Walls Thermal-Grip® Insulation Pin
- ▶ Sealants (Rmax R-SEAL 2000 LF, Sika Sikasil® WS-295, Sika® SikaHyflex®-407, Henry Company Henry® 925 BES)
- ▶ Primers (Berry Global Polyken® 44SA, Polyken® 1027 or Nashua® 357SA)
- ▶ Backer rods (Sika Corp Sika® Backer Rod)
- ▶ Polyurethane expansion foam (Sika Corp Sika Boom®)
- ▶ Tools, as needed based on materials and installation technique (2500 rpm impact driver, squeegee and/or J-roller, caulking gun and tips)
- ▶ Marking tool (marker, chalk line, etc.)
- ▶ Personal Protective Equipment (hard hat, safety glasses, safety vest, work gloves)

†Components have been tested together to pass fire, air and water system standards – substitution is NOT allowed.

GETTING STARTED

- Rmax recommends that only skilled, trained contractors and installers familiar with air and water sealing techniques and building envelope systems be used to perform the required work.

NOTE: High quality products do not take the place of poor quality installation.

- Continually inspect all wall assembly materials and substrates for any damage and proper installation. Do not install the ECOMAXci® Wall Solution components or other materials over damaged or improperly installed substrates. Do not install any damaged components or materials.
- Once all products have been inspected and accounted for, installation may begin.
- Do not install the ECOMAXci® Wall Solution during adverse weather conditions (rain, sleet, snow, heavy winds, etc.).
- Do not install or seal wet or damaged construction materials within a wall assembly (gypsum sheathing, wood sheathing, cavity insulation, continuous insulation, tapes, flashings, etc.).
- Ensure all building materials are completely dry before installing, sealing or covering.
- Fasten ECOMAXci® FR Air Barrier completely by the end of each working day.

**FOR BEST PRACTICE AND TO RESIST MOISTURE INTRUSION THROUGH THE BUILDING ENVELOPE,
SEAL ALL JOINTS AND SEAL OR PROTECT BOARD EDGES AT THE END OF EACH DAY.**

STEP BY STEP INSTALLATION

Throughout this document, base wall refers to steel stud, fire-retardant-treated (FRT) wood stud, concrete and CMU, as applicable.

Unless specifically stated otherwise, all references to joints within this document are assumed to be static. **See Section 5** for expansion, control and other dynamic joints.

1. ECOMAXci® FR Air Barrier Continuous Insulation Boards

- A. Only remove the wrap from the bundles that are to be installed that day.
- B. Insulation boards are lightweight and must be handled with care, especially during windy days.
- C. Apply ECOMAXci® FR Air Barrier to smooth surfaces free of under driven fasteners, holes, ridges or depressions that will affect the placement or performance of the insulation boards. All surface irregularities, such as low or high spots, should be repaired so the surface is flat to receive the insulation boards. It is the responsibility of the contractor and installer to ensure that the system is properly prepared to receive the insulation boards. Do not score, slash or otherwise cut either facer of the insulation board in order to force the panel to conform to wall irregularities.
- D. Ensure substrate is free of water and surface moisture.
- E. Start at the end of a wall section. Install the insulation boards on the wall with the long dimension horizontal and vertical edges backed by structural framing/base wall. Insulation boards must be plumb and level. Orient the insulation boards with the Rmax Solutions shield logo facing the exterior.
- F. Where insulation boards need to be cut to fit, the insulation must be large enough to ensure vertical joints are backed by structural framing/base wall, and where possible, at least 12" in either direction.
- G. Tightly butt insulation boards.
- H. With steel and FRT wood studs, center joint over framing with each board bearing a minimum of 1/2". Continue installing ECOMAXci® FR Air Barrier horizontally across the wall before starting a new row of panels. Stagger each row of insulation boards a minimum of 6" (or one stud space) to the row below.
- I. Where possible, extend bottom edge of boards a minimum of 1" below the top of the foundation or structure. Ensure the top edge of the highest row of insulation boards along each wall is flush with the top of the parapet or framing/base wall.
- J. Do not span the insulation board across materials that are out of plane more than 1/4".
- K. For changes in direction (corners, surface offsets, etc.) the boards should tightly fit in an overlap. **Reference Figure 1 and 8.**
- L. Where the insulation board is cut to accommodate throughwall penetrations, minimize voids and gaps.
- M. Repair minor damage to the aluminum facer using R-SEAL 3000. **Reference step 3-K.**
- N. Replace major damage (missing sections) to the foam core or aluminum facer by fully cutting out the damaged area. The removed piece is recommended to be the full height of the board, and must be cut wide enough to ensure new vertical joints are backed by structural framing/base wall and a minimum of 6" beyond the damaged area in all directions. Cut a new piece of ECOMAXci® FR Air Barrier insulation board to tightly fill the open area. Fasten and seal the new piece as outlined in this document.

NOTE: ECOMAXci® FR Air Barrier may be installed in multiple layers. Stagger all joints of subsequent layers at least 6" horizontally (or one stud spacing) and a minimum of 6" vertically. Provided the second layer is being installed immediately following the installation of the first layer, attach the first layer with enough fasteners to hold it in place until the second layer is attached per **Section 2**. In this scenario, only the final layer needs to be sealed. If the second layer is not being installed immediately, this document must be followed for each layer independently.

MATERIAL & LABOR SAVINGS

Rmax recommends using ECOMAXci® FR Air Barrier in 12' lengths to minimize the number of joints and reduce the linear footage of joint tape.

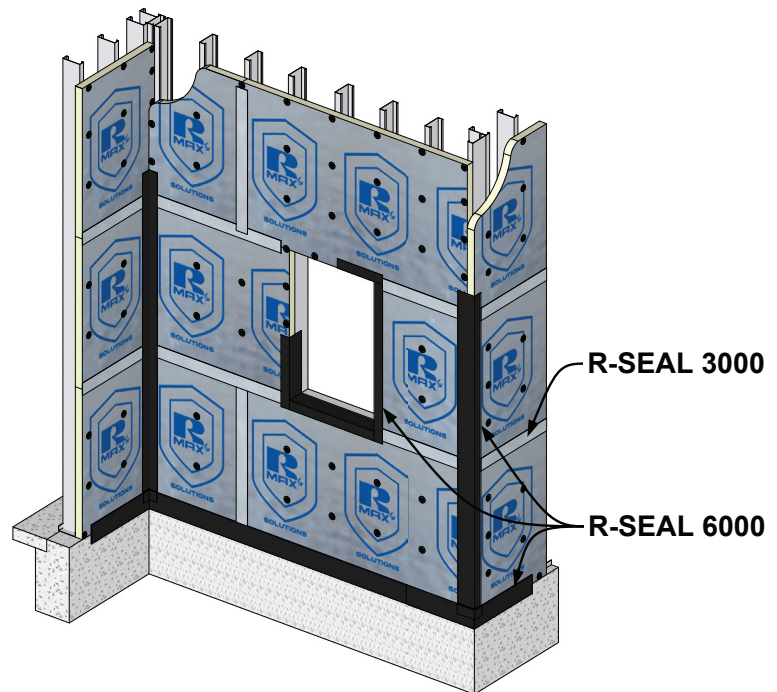

Figure 1

Maximum Fastening Pattern of ECOMAXci® FR Air Barrier

Nominal Insulation Thickness	Steel or FRT Wood Studs ¹		Concrete and CMU ¹
	Wall & Rough Opening Perimeters	Field Studs	Perimeters ² & Fields
Less than 1.5"	12" o.c. ³	16" o.c. ³	1 fastener/4 sqft (~24" o.c.) ⁴
	Figure 2		Figure 4
1.5" and greater	24" o.c. vertically ³ ; Match stud spacing horizontally	24" o.c. ³	1 fastener/4 sqft (~24" o.c.) ⁴
	Figure 3		Figure 4

¹All vertical edges must be backed by structural framing/base wall.
²Perimeter fasteners must be within 6 inches of the edge of the board.
³No less than a total of 4 fasteners per board.
⁴No less than a total of 2 fasteners per board.

Table 1

2. Insulation Board Securement

A. Fasteners

i. **Steel Stud:** Mechanically fasten insulation boards to wall framing using a minimum 2" diameter solid plastic washers and self-taping corrosion-resistant steel screws, such as Trufast Walls Thermal-Grip®ci Prong Washers and Grip-Deck® Self-Drilling Screws or equivalent, as determined by material manufacturer.

ii. **FRT Wood Stud:** Mechanically fasten insulation boards to base wall using a minimum 2" diameter solid plastic washer and corrosion-resistant steel screw, Trufast Walls Thermal-Grip®ci Prong Washers and Grip-Deck® HiLo Thread Screws or equivalent, as determined by material manufacturer.

iii. **Concrete and CMU:** Mechanically fasten insulation boards to base wall using a minimum 2.25" diameter plastic washer anchor system, such as Trufast Walls Plasti-Grip® PMF, Thermal-Grip® Insulation Pin or equivalent, as determined by material manufacturer.

B. **Fastening Pattern:** Secure insulation boards in accordance with **Table 1** based on nominal insulation thickness and base wall.

C. **Fastener Installation:** Fasteners must be long enough to penetrate the wall framing a minimum of four threads into steel stud and 1" into FRT wood stud. Refer to concrete anchor manufacturer for minimum penetration. Install fasteners to fit tight and flush with the insulation board surface, see fastener manufacturer for additional details and requirements. Do not crease or break the aluminum facer of the boards. Do not counter sink fasteners. If the aluminum facer is compromised, seal/repair with R-SEAL 3000 as outlined in **Section 3**.

D. **Bridging Insulation Boards:** Use one fastener to bridge a maximum of three adjacent boards.

Reference Figure 5. When bridging boards, center fastener at intersection of board joints to maximize washer surface on each board.

E. **Fastener Installation Errors:** Fastener installation errors (misaligned, missed framing, spun out, over-driven, under-driven, etc.) must be corrected and repaired. Remove fastener and repair area with R-SEAL 3000 as outlined in **Section 3**, then reinstall fastener in unaffected area.

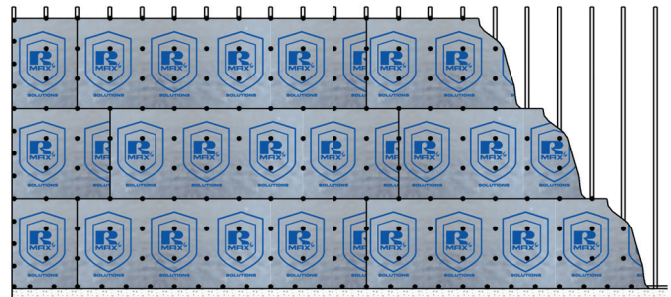

Figure 2

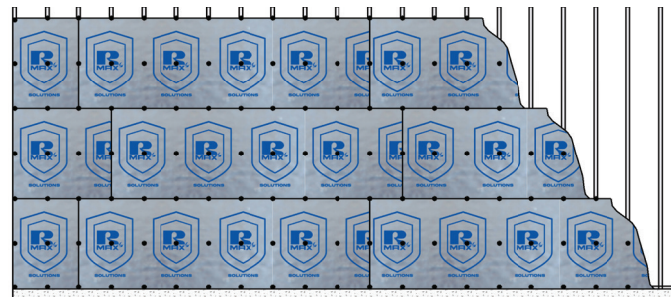

Figure 3

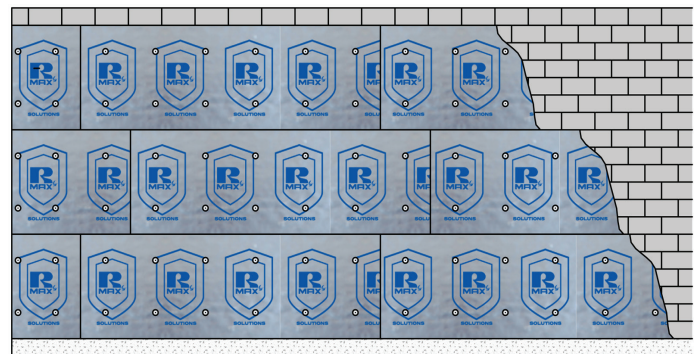

Figure 4

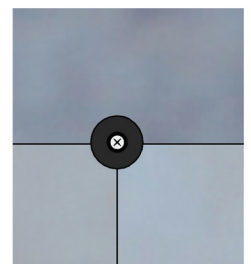

Figure 5

3. R-SEAL 3000 Tape

MORE PRESSURE
GREATER SURFACE CONTACT
BETTER ADHESION

NOTE: In areas where R-SEAL 3000 and R-SEAL 6000 overlap, always apply R-SEAL 3000 first.

A. Use R-SEAL 3000 to seal all static insulation board joints and repair minor damage to the aluminum facer. Refer to the R-SEAL 3000 data sheet for information on appropriate installation conditions.

B. All surfaces to which the tape is to be applied must be sound, clean and free of moisture, frost, oils, grease, dust, dirt and other debris that could inhibit adhesion. Immediately prior to application, clean surfaces to thoroughly remove all residues and any other foreign matter. Exercise care when handling tape to avoid contaminating adhesive.

C. The ECOMAXci® FR Air Barrier foam core does not support adhesion and is not to be considered the last surface of any taping sequence. Tape must extend beyond the foam core on either side.

D. Treat, prime or otherwise prepare surfaces as necessary (FRT lumber, concrete, coatings, etc.). Fill holes, voids and gaps greater than 1/4".

NOTE: Substrates vary in makeup. A field pull test to confirm adhesion is always recommended.

E. **Tooling:** Apply firm, uniform pressure from the center out using a roller, plastic squeegee or similar tool to smooth out wrinkles and ensure complete surface contact with substrate embossment or other surface irregularities. As necessary, extend tape to ensure complete contact with the intended substrate, especially where irregularities exist (indentions, gaps, wrinkles, creases, etc.).

NOTE: R-SEAL 3000 is a pressure sensitive tape. Firm, uniform pressure is critical to create surface contact and achieve proper adhesion.

F. **Lapping:** When two layers of R-SEAL 3000 join, overlap a minimum of 2".

G. **Insulation Board Joints:** Apply tape in a shingle fashion, i.e., start at the bottom and work up. Center tape at joint within 1/4".

H. **Joint Fasteners:** Fully cover with R-SEAL 3000 to maintain a minimum of 3/4" adhesion to facer beyond washer edges. **Reference Figure 6.**

I. **Field Fasteners:** When NOT using Trufast Walls Thermal-Grip®ci Prong Washers and Grip-Deck® Self-Drilling Screws, field fasteners must be covered by R-SEAL 3000. Maintain a minimum 3/4" adhesion radially beyond washers, similar to **Figure 6.**

J. **Correcting Fastener Installation Errors:** Use R-SEAL 3000 to seal fastener installation errors (misaligned, missed framing, spun out, over-driven, under-driven, etc.). Remove fastener and seal with a minimum 4"x4" patch centered over damaged area. The tape should be adhered a minimum of 2" radially beyond any damage.

K. **Minor Damage to Aluminum Facer or Foam Core:** Use R-SEAL 3000 to seal areas with minor damage, extending a minimum of 2" beyond the damaged location. Apply tape in a shingle fashion, where applicable.

L. Do not allow the tape to tent, form voids or buckle. For tape that is tented, wrinkled, folded over on itself, fish-mouthed, or otherwise damaged, remove and replace. If removing tape causes damage to the facer, leave original layer of tape in place and use an additional layer(s) of tape to create a properly sealed transition.

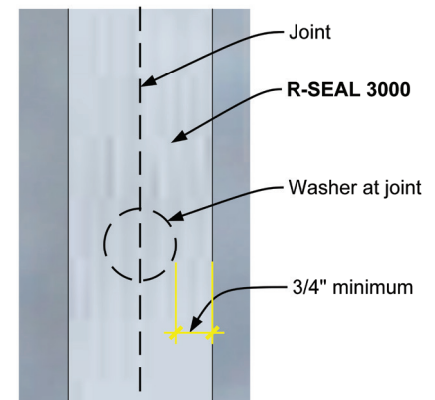

Figure 6

4. R-SEAL 6000 Flashing

NOTE: In areas where R-SEAL 3000 and R-SEAL 6000 overlap, always apply R-SEAL 3000 first.

A. Use R-SEAL 6000 to seal insulation boards at corners, rough openings, throughwall penetrations and transitions. Refer to the R-SEAL 6000 data sheet for information on appropriate installation conditions.

B. All surfaces to which the flashing is to be applied must be sound, clean and free of moisture, frost, oils, grease, dust, dirt and other debris that could inhibit adhesion. Immediately prior to application, clean surfaces to thoroughly remove all residues and any other foreign matter. Exercise care when handling tape to avoid contaminating adhesive.

C. The ECOMAXci® FR Air Barrier foam core does not support adhesion and is not to be considered the last surface of any flashing sequence. Flashing must extend beyond the foam core on either side.

D. Treat, prime or otherwise prepare surfaces as necessary (FRT lumber, concrete, coatings, etc.). Fill holes, voids and gaps greater than 1/4".

NOTE: Substrates vary in makeup. A field pull test to confirm adhesion is always recommended.

E. Always install flashing in a shingle fashion, i.e., start at the bottom and work up.

F. **Tooling:** Apply firm, uniform pressure from the center out to the edge using a roller, plastic squeegee or similar tool to smooth out wrinkles and ensure complete surface contact with substrate embossment or other surface irregularities. Extend flashing to ensure complete contact with the intended substrate, especially where irregularities exist (indentions, gaps, wrinkles, creases, etc.).

NOTE: R-SEAL 6000 is a pressure sensitive flashing. Firm, uniform pressure is critical to create surface contact and achieve proper adhesion.

G. **Lapping:** When two layers of R-SEAL 6000 join at a horizontal or vertical application, overlap a minimum of 3" and apply R-SEAL 2000 LF or equivalent sealant along both edges where the overlap occurs. The sealant should extend radially beyond the pinholes potentially created by the overlap. **Reference Figure 7.**

H. **Fasteners:** Fully cover fasteners that fall within the flashed area with R-SEAL 6000 to maintain a minimum of 1" adhesion to the surface beyond the washer edges.

I. **Corners:** Use R-SEAL 6000 to bridge adjacent insulation boards at corners. Apply at the bottom of the wall and work up extending flashing a minimum of 3" onto each facer (beyond the foam core). **Reference Figure 8.**

NOTE: For best practice, apply a fillet of R-SEAL 2000 LF or other sealant in the corner prior to applying the R-SEAL 6000.

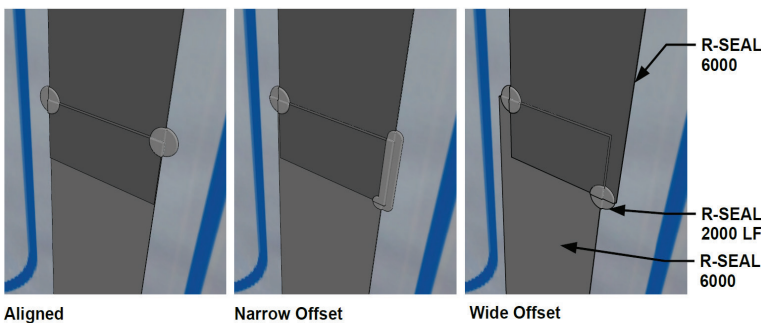

Figure 7

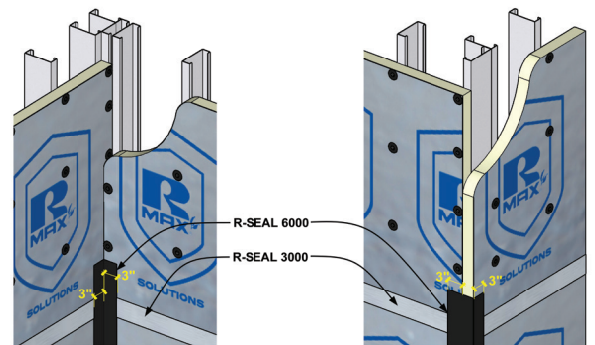

Figure 8

J. **Rough Openings:** Apply sill flashing first, then bottom corner patches. Next, apply flashing at the jambs, then upper corner patches. Finally, apply head flashing. Head flashing must extend at least 1" beyond jamb flashing on both sides. **Reference Figure 9.** For each plane to be flashed, extend flashing a minimum of 3" onto the surface of the last substrate and a minimum of 1" beyond any washer. **Reference Figure 10.** Corner patches are critical to ensure continuity in the corners at flashing transitions. They are typically pre-cut pieces of R-SEAL 6000 in the shape of a circle, bowtie or bootstrap. **Reference Figures 11.** Alternatively, use pre-formed end dams.

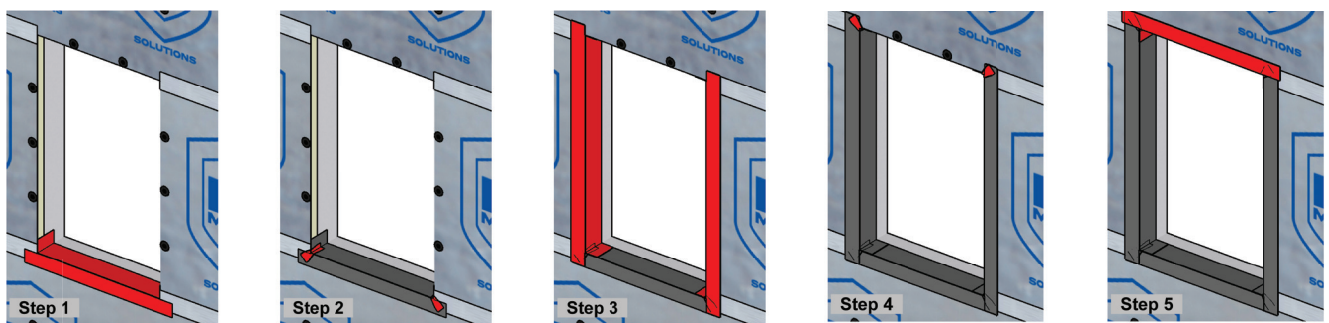

Figure 9

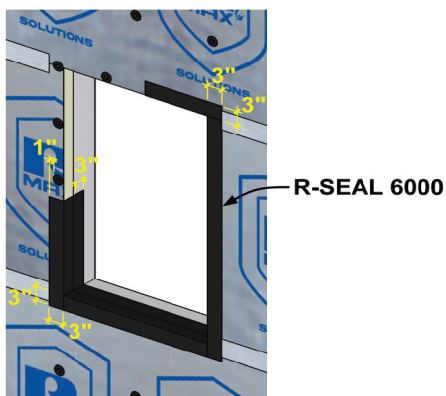

Figure 10

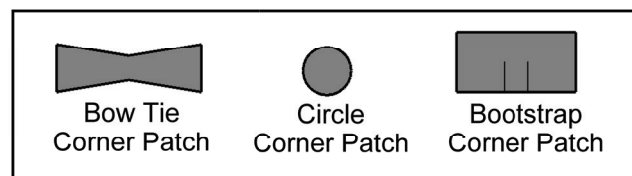

Figure 11

K. Throughwall Penetrations: **Reference Figures 12-16** for flashing details of various throughwall penetration types and sizes utilizing multiple installation techniques. In all cases, flashing should overlap preceding pieces at least 1". When wrapping penetrations, ensure lap points downward to simulate shingle fashion.

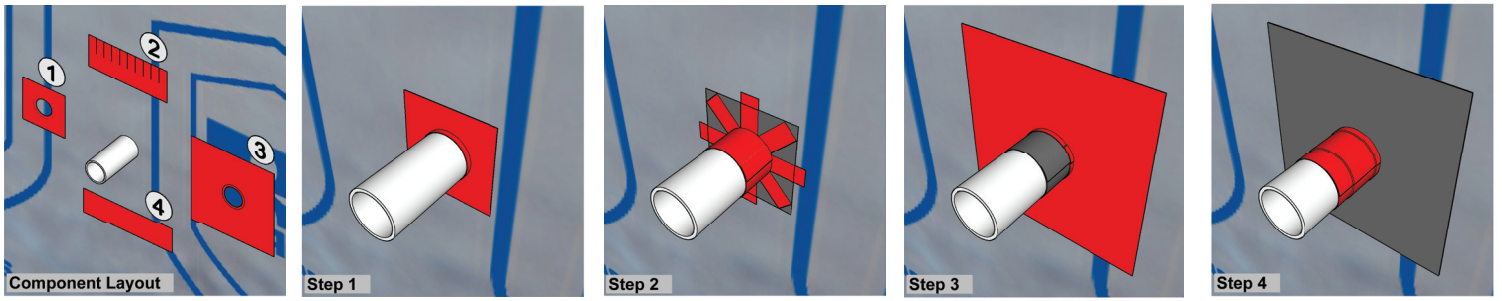

Figure 12

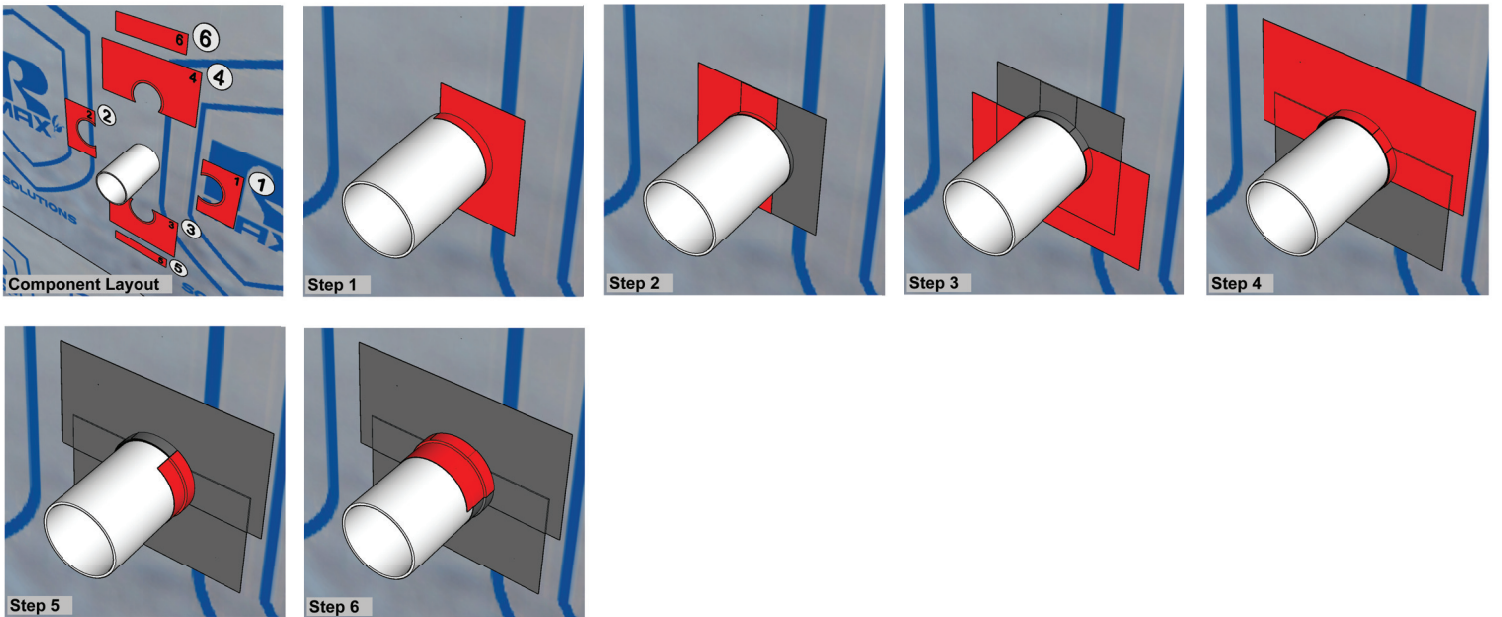

Figure 13

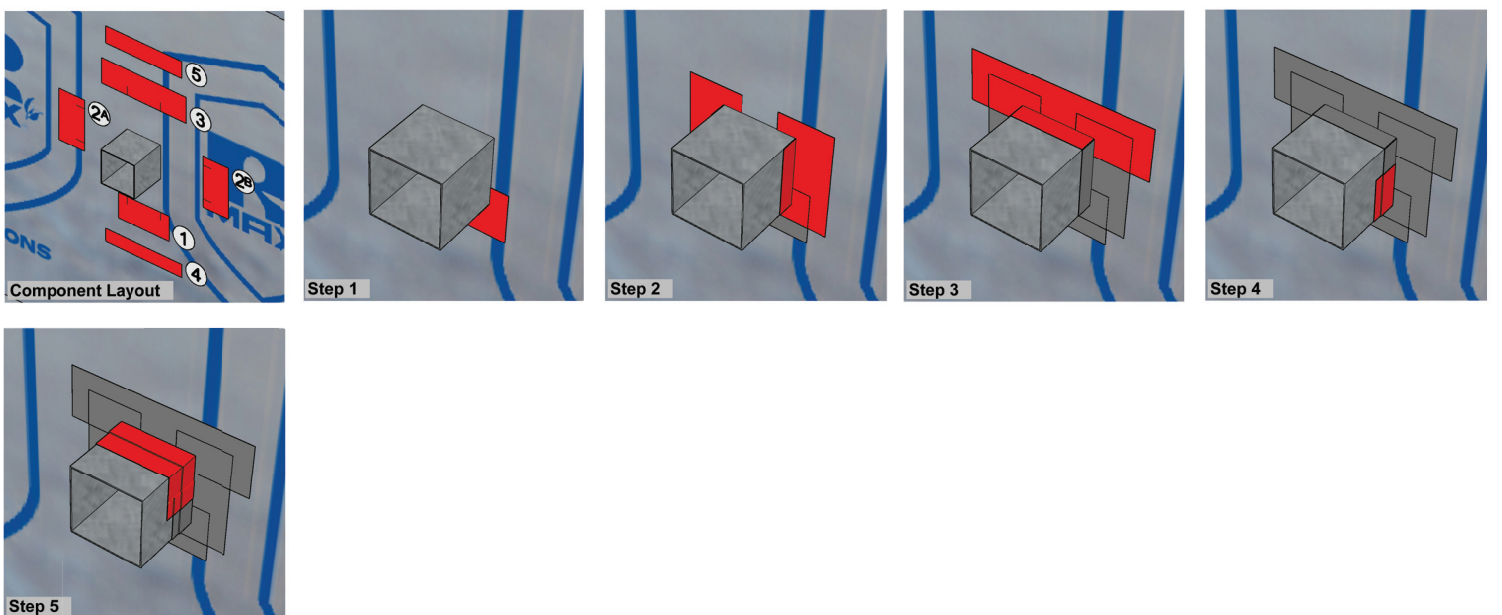

Figure 14

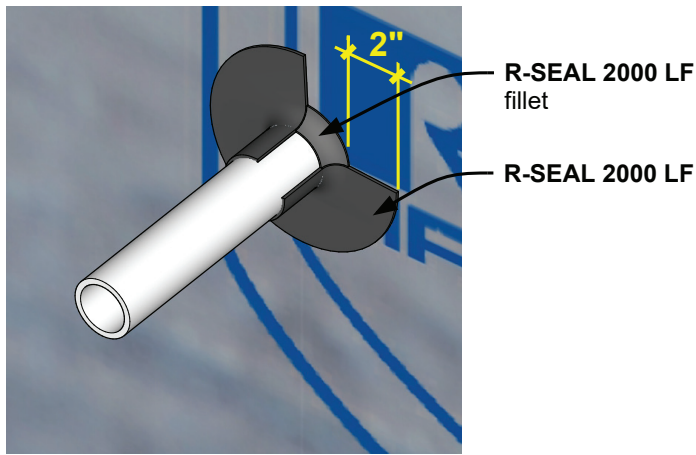

Figure 15

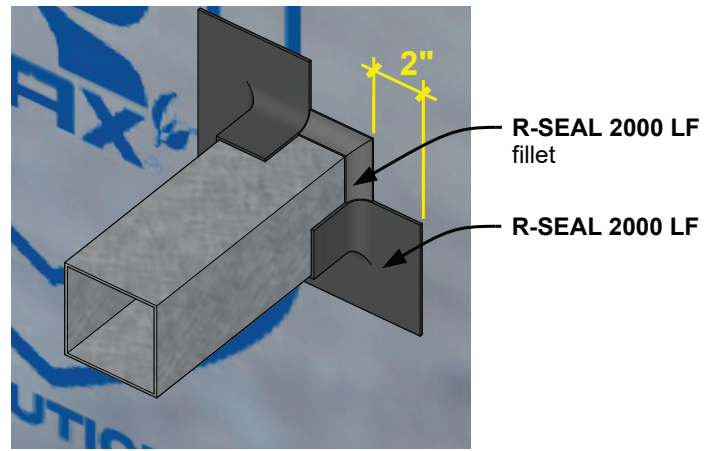

Figure 16

L. Transitions (foundations, slabs, shelf protrusions, roofing membranes, blocking, etc.): Use R-SEAL 6000 (where compatible with adjacent materials) at board terminations to transition into alternate substrates and maintain a continuous air and water-resistive barrier. Extend flashing a minimum of 3" each onto the aluminum facer and suitable adjacent substrate.

M. Do not allow the flashing to tent, form voids, or buckle. For flashing that is tented, wrinkled, folded over on itself, fish-mouthed, or otherwise damaged, remove and replace. If removing flashing causes damage to facer, an additional layer of flashing should be applied to create a properly sealed transition.

5. Expansion, Control and Other Dynamic Joints

- A. This section applies to all joints subject to movement.
- B. An insulation board must never span a dynamic joint. Cut the insulation board to create a joint as necessary.
- C. Do not use fasteners to bridge insulation boards at dynamic joints; boards must be fastened separately on both sides of the joint.
- D. For dynamic joints up to $\frac{3}{4}$ ", R-SEAL 6000 flashing may be used to seal the insulation boards. Install a backer rod and/or bond breaker as required and loop flashing inside the joint to allow for movement.

Reference Figure 17. The R-SEAL 6000 must extend a minimum of 3" onto each surface. Loop dimensions will vary based on joint performance requirements.

- E. For expansion joints greater than $\frac{3}{4}$ ", do not use R-SEAL 6000 to loop or bridge joint. Refer to Construction Documents for proper detailing. Ensure air and water-resistive barrier is continuous.

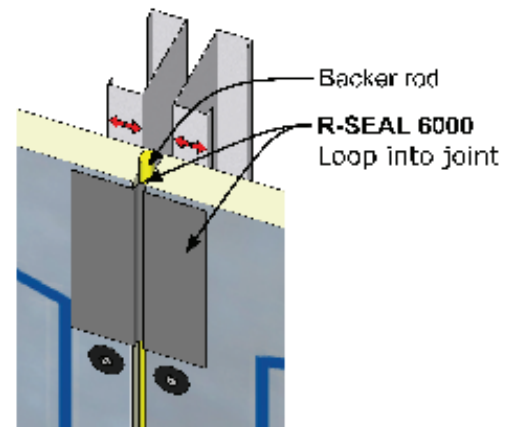

Figure 17

6. Future Trades (Exterior Facade Installation, Wall Penetrations, etc.)

- A. Begin work by future trades only after all taping and flashing of the ECOMAXci® Wall Solution has been completed within that section.
- B. Take care to minimize damage to installed wall components (insulation board facer or foam core, tapes, flashings, etc.) so as not to break the continuous air and water-resistive barrier provided by the ECOMAXci® Wall Solution.
- C. All damage must be repaired as detailed previously throughout this document. Damage includes misaligned fasteners, loose fasteners, holes, tool damage, etc.
- D. ECOMAXci® FR Air Barrier insulation board is non-structural and must not be used to support any exterior cover materials. All elements (mechanical, façade, etc.) penetrating the ECOMAXci® Wall Solution must be securely attached through the insulation boards directly to the structural framing/base wall.
- E. Use common construction practices of maintaining the air and water-resistive barrier provided by the ECOMAXci® Wall Solution with all trade work (anchor penetrations, wall penetrations, etc.). Examples of acceptable sealing techniques include:
- Center a piece of commercial grade flashing with 100% butyl rubber adhesive, such as R-SEAL 6000, on the aluminum surface of the board before penetrating with structural screws.
 - Seal barrel style exterior anchor penetrations, such as Heckmann Building Products Pos-I-Tie®, with either a one part moisture cure sealant, such as R-SEAL 2000 LF, Henry 925, or equivalent.
 - Sealants are not required in the field of the insulation board with Trufast Walls Thermal-Grip® Brick Tie Washers with Barrel Style Brick Ties.
 - Seal wall penetrations with a silicone or STPe sealant, such as Sika Sikasil® WS-295 or R-SEAL 2000 LF, or equivalent.
- F. Shim attachment elements, such as horizontal furring, a minimum of $\frac{3}{16}$ " to ensure proper gapping for positive drainage.

TIPS AND BEST PRACTICES

The following do not take the place of installation instructions contained within this document:

- Substrates vary in makeup. A field pull test to confirm adhesion is always recommended.
- For added protection, counter flash R-SEAL 6000.
- R-SEAL 2000 LF or R-SEAL 3000 may be used as counter-flashing.
- Install flashing at the rough openings to the full depth of the sill, jambs, and header.
- When using a polyurethane expansion spray foam (or similar material) to fill gaps, allow material to fully cure. Then cut off excess to create a flat surface with adjacent materials prior to applying tape or flashing. Extend R-SEAL products onto clean surfaces (beyond any overspray or residue) the minimum distance required throughout this document.
- Priming is not usually necessary for the aluminum facer of ECOMAXci® FR Air Barrier, steel or untreated wood under normal conditions. While priming can improve adhesion it does not dismiss the requirement for proper surface preparation.
- For rough surfaces and treated, textured or porous materials (OSB, FRT wood, concrete, etc.), it is recommended that a primer be used to promote adhesion between R-SEAL 6000 and the substrate. Recommended primers include Polyken® 44SA, Polyken® 1027 or Nashua® 357SA from Berry Global. Always confirm appropriate, compatible use with both substrates.
- For convenience, mark the facer and other substrates the required distance for tapes and flashings prior to installation.
- Use a drive guide or bit sleeve when installing screws to hold washer in place, reduce fastener wobble, and protect hands.
- Rmax highly recommends all details of the ECOMAXci® Wall Solution be discussed during all preconstruction meetings and mock-ups. Confirmatory testing, such as ASTM E779, E1827, or E3158, should be done before the cladding is attached to allow time and access to correct any errors.

“How To” videos can be found online at <https://www.rmax.com/education/videos>.

NOTE: The videos are meant to supplement these instructions, not take the place of them.

TRUSTED STANDARDS. TRUSTED PRODUCTS.

RMAX IS CERTIFIED
CLEAN AIR GOLD

Proves our credibility in providing **SAFE, RELIABLE,**
and **ECO-CONSCIOUS** polyiso insulation products.



CERTIFIED
CLEAN AIR GOLD

Clean Air Gold Certification demonstrates that Rmax polyiso insulation products meet the criteria for low-emitting construction materials, California Department of Public Health (CDPH) Standard Method V1.2. Proving that Rmax has more sustainable products with the health and safety of consumers, space inhabitants, and builders/fabricators in mind.

abaa
EVALUATED

air barrier assembly

air barrier
abaa
association of
america

Rmax ECOMAXci® Wall Solution is **ABAA EVALUATED** as an air barrier assembly, approved water-resistive barrier and engineered to optimize continuous insulation.

RMAX, SIKA BUSINESS UNIT
2075 Midway Road
Lewisville, TX 75056
1-800-527-0890
rmax.com

FOR WARRANTIES, LIMITATIONS AND CONDITIONS
refer to Rmax Sales Policy and applicable warranties located at rmax.com

FOR SALES SUPPORT, PRICING AND AVAILABILITY
email rmax@rmax.com or call (800) 527-0890

FOR TECHNICAL SUPPORT
email rmax.technical@us.sika.com

DESIGNED
ENGINEERED
MANUFACTURED
Proudly in the USA



PIMA
POLYISOCYANURATE INSULATION
MANUFACTURERS ASSOCIATION



INSTALLATION GUIDE
ECOMAXCI® WALL SOLUTION
Revision.02-24-2023



BUILDING TRUST

